

# Datasheet

## Tianma

P1500XGF3MA00

TI-01-038





## CONTENTS

1. Summary .....	4
1.1 General Description .....	4
1.2 Features .....	4
2. General Specifications .....	5
3. Input /Output Terminals .....	6
4. Absolute Maximum Ratings.....	10
5. Electrical Characteristics .....	11
6. Timing Chart.....	15
7. Optical Characteristics .....	24
8. Environmental / Reliability Test.....	27
9. Mechanical drawing .....	28
10. Packing Drawing.....	29
11. Precautions for Use of LCD Modules.....	30

## **1. Summary**

### **1.1 General Description**

This is a 15 inch a-Si TFT-LCD module with Normal- black technology. It is composed of a TFT-LCD panel, a driver circuit, PCBA, BEZEL, and a LED backlight unit.

### **1.2 Features**

- Ultra-wide viewing angle (Super Fine TFT (SFT) )
- 50Khrs Long LED life time
- Interface: LVDS
- With LED driver
- Compliant with the European RoHS Directive (2011/65/EU) and Delegated Directive (2015/863/EU, Amending Annex II of 2011/65/EU)

## 2. General Specifications

Feature		Spec
<b>Display Spec.</b>	Size (inch)	15
	Resolution	1024*768
	Technology Type	SFT
	Pixel Configuration	B.G.R vertical stripe
	Pixel Pitch (mm)	0.297 x 0.297
	Display Mode	Transmissive, Normally Black
	Surface Treatment (Up Polarizer)	Antiglare
<b>Optical Characteristics</b>	Luminance (cd/m2)	1500 min.
	Contrast ratio	1000:1 Typ.
	Response time Ton+Toff (ms)	25 Typ.
	Viewing angle R/L/U/D (Degree)	89/89/89/89 Typ
<b>Mechanical Characteristics</b>	LCM (W x H x D) (mm)	326.5 x 253.5 x 13 Typ.
	Active Area (mm)	304.128 x 228.096
	With /Without TSP	Without TSP
	Weight (g)	1048g
<b>Electrical Characteristics</b>	Interface	1port LVDS
	Power supply voltage (V)	LCD panel: 3.3 Typ.
		Backlight: 12.0 Typ.
	Color Depth	16,194,277 colors (At 8-bit input, FRC terminal= Low)
		262,144 colors (At 6-bit input, FRC terminal=High or Open)
	Backlight LED driver	Build in LCM
Power consumption (W)	LCD+Backlight: 33.68W	

Note 1 : Requirements on Environmental Protection: Q/S0002+UL

Note 2 : LCM weight max. tolerance : +10%

### 3. Input /Output Terminals

#### 3.1 TFT LCD Panel

CN1 socket (LCD module side): MSB240420HE ( STM )

Adaptable plug: TBD

Pin No.	Symbol	Signal	Input data signal: 8-bit	Input data signal: 6-bit	Remarks
1	VCC	Power supply	Power supply		Note2
2	VCC				
3	GND	Ground	Ground		Note2
4	DPS	Selection of scan direction	High : Low or Open :	Reverse scan Normal scan	Note3
5	D0-	Pixel data	R0-R5, G0		Note1
6	D0+				
7	GND	Ground	Ground		Note2
8	D1-	Pixel data	G1-G5, B0-B1		Note1
9	D1+				
10	GND	Ground	Ground		Note2
11	D2-	Pixel data	B2-B5, DE		Note1
12	D2+				
13	GND	Ground	Ground		Note2
14	CLK-	Pixel clock	Pixel clock		Note1
15	CLK+				
16	GND	Ground	Ground		Note2
17	D3-/ GND	Pixel data / Ground	R6-R7 G6-G7 B6-B7	Ground	Note1
18	D3+/ GND				
19	N.C.	Non connection	-		Keep this pin Open
20	FRC	Selection of the number of colors	Low	High or Open	Note4, Note5

Note1: All GND and VCC terminals should be used without any non-connected lines.

Note2: Twist pair wires with 100Ω (Characteristic impedance) should be used between LCD panel signal processing board and LVDS transmitter.

Note3: See "**6.6 SCANNING DIRECTIONS**".

Note4: See "**6.4 DISPLAY COLORS AND INPUT DATA SIGNALS**".

Note5: See "**2.4 Connection between receiver and transmitter for LVDS**".

The information contained herein is the exclusive property of Tianma Microelectronics Co., Ltd., and shall not be distributed, reproduced, or disclosed in whole or in part without prior written permission of Tianma Microelectronics Co., Ltd..

**3.2 Backlight**

CN2 socket (LCD module side): 5040501291(Molex)  
 Adaptable plug: TBD

Pin No.	Symbol	Signal	Remarks
1	VDD	Backlight power input	
2	VDD	Backlight power input	
3	VDD	Backlight power input	
4	VDD	Backlight power input	
5	GND	Backlight power GND	
6	GND	Backlight power GND	
7	GND	Backlight power GND	
8	GND	Backlight power GND	
9	NC	Non connection	
10	NC	Non connection	
11	BRTC	Backlight ON/OFF EN	
12	PWM	Backlight PWM	

Note1: All GND and VDD terminals should be used without any non-connected lines.

**3.3 Positions of Socket**

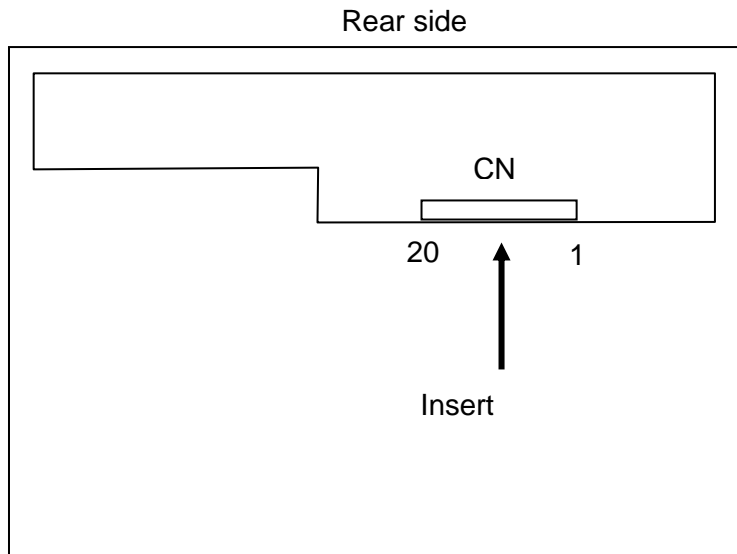

**3.4 Connection between receiver and transmitter for LVDS**

(1) LVDS Input data signal: 8-bit (FRC: Low)

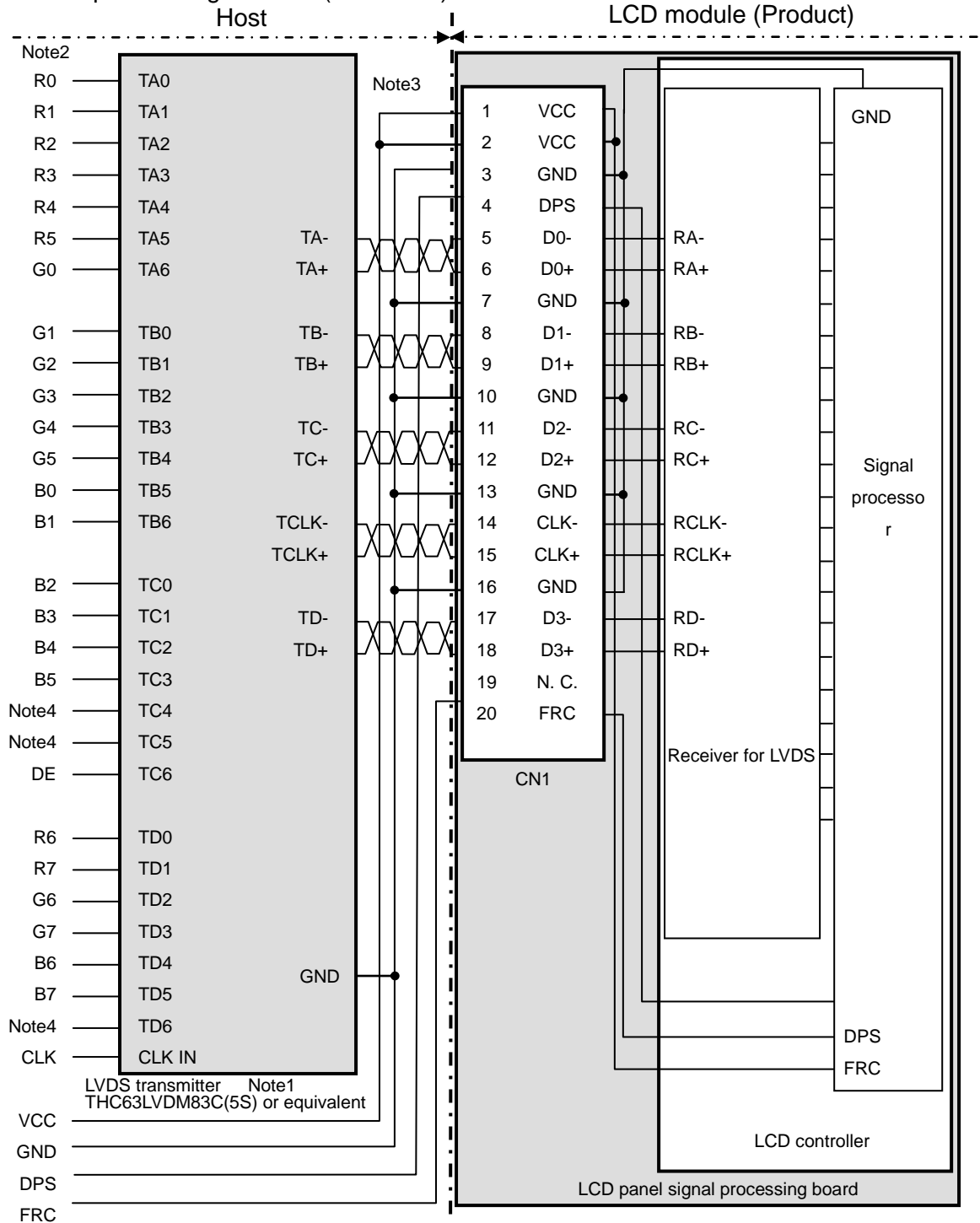

Note1: Recommended transmitter: THC63LVDM83C (5S) (THine Electronics Inc.) or equivalent.

Note2: LSB (Least Significant Bit) - R0, G0, B0. MSB (Most Significant Bit) - R7, G7, B7

Note3: Twist pair wires with 100Ω (Characteristic impedance) should be used between LCD panel signal processing board and LVDS transmitter.

Note4: Input signals to TC4, TC5 and TD6 are not used inside the product, but do not keep them open to avoid noise problem.

The information contained herein is the exclusive property of Tianma Microelectronics Co., Ltd., and shall not be distributed, reproduced, or disclosed in whole or in part without prior written permission of Tianma Microelectronics Co., Ltd..

(2) LVDS Input data signal: 6-bit (FRC: High or Open)

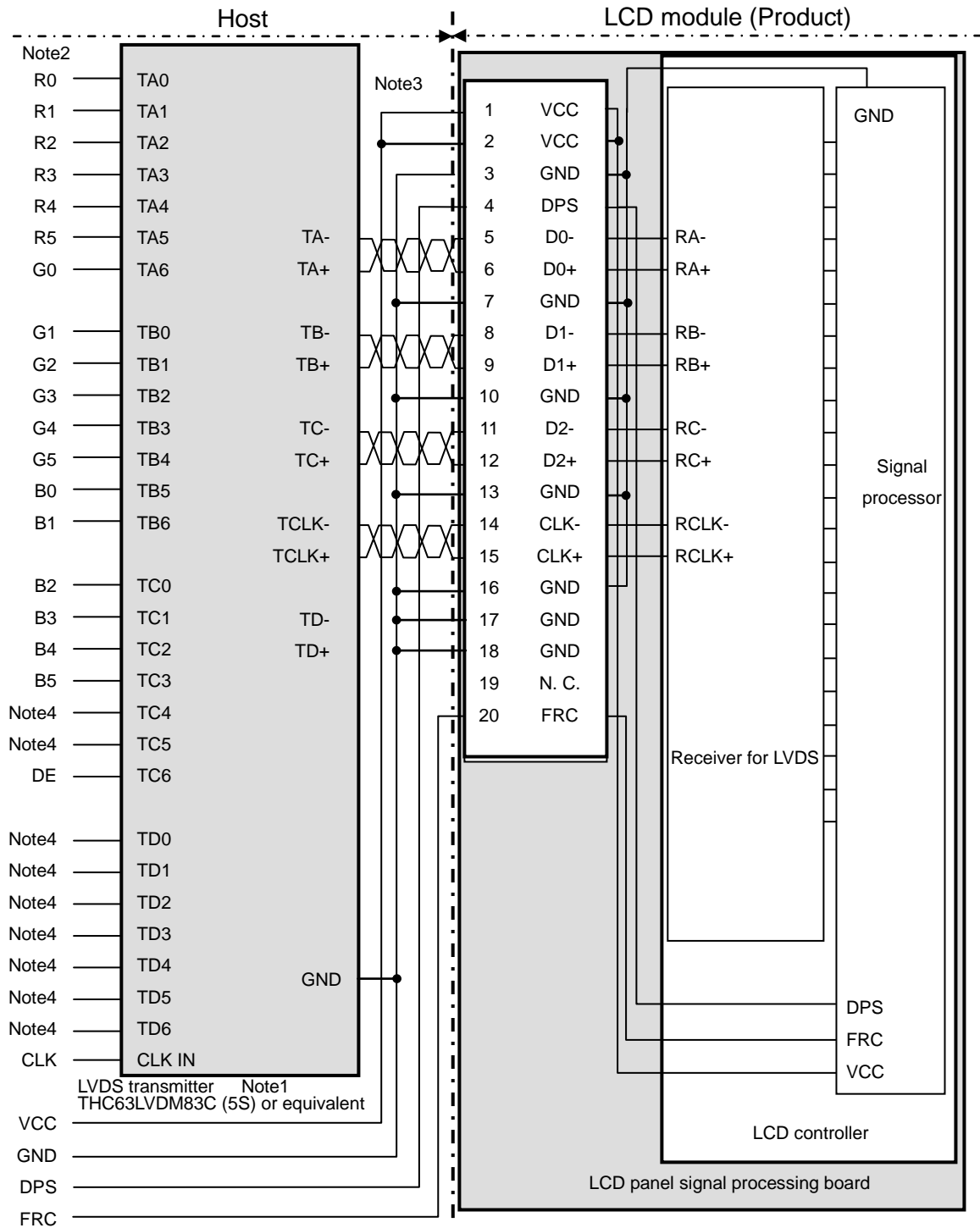

Note1: Recommended transmitter: THC63LVDM83C (5S) (THine Electronics Inc.) or equivalent.

Note2: LSB (Least Significant Bit) - R0, G0, B0. MSB (Most Significant Bit) - R5, G5, B5

Note3: Twist pair wires with 100Ω (Characteristic impedance) should be used between LCD panel signal processing board and LVDS transmitter.

Note4: Input signals to TC4, TC5 and TD0-6 are not used inside the product, but do not keep them open to avoid noise problem.

#### 4. Absolute Maximum Ratings

Parameter		Symbol	Rating	Unit	Remarks	
Power supply voltage	LCD panel signal processing board	VCC	-0.3 to +3.96	V	Ta= 25°C	
	LED driver	VDD	-0.3 to +15.0			
Input voltage for signals	Display signals Note1	VD	-0.5 to VCC+0.3	V		
	Function signals Note2	VF	-0.5 to VCC+0.3	V		
	Function signal for LED driver	PWM	-0.3 to +5.5	V		
		BRTC	-0.3 to +5.5	V		
Storage temperature		Tst	-30 to +80	°C		-
Operating temperature	Front surface	TopF	-20 to +70	°C		Note3
	Rear surface	TopR	-20 to +70	°C	Note4	
Relative humidity Note5		RH	≤ 95	%	Ta ≤ 40°C	
			≤ 85	%	40°C < Ta ≤ 50°C	
			≤ 55	%	50°C < Ta ≤ 60°C	
			≤ 36	%	60°C < Ta ≤ 70°C	
Absolute humidity Note5		AH	≤ 70 Note6	g/m <sup>3</sup>	Ta > 70°C	

Note1: D0+/-, D1+/-, D2+/-, D3+/- and CLK+/-

Note2: DPS and FRC

Note3: Measured at LCD panel surface (including self-heat)

Note4: Measured at LCD module's rear shield surface (including self-heat)

Note5: No condensation

Note6: Water amount at Ta= 70 °C and RH= 36%

## 5. Electrical Characteristics

### 5.1 Driving TFT LCD Panel

(Ta= 25°C)

Parameter	Symbol	min.	typ.	max.	Unit	Remarks	
Power supply voltage	VCC	3.0	3.3	3.6	V	-	
Power supply current	ICC	-	187.8	-	mA	at VCC= 3.3V	
Permissible ripple voltage	VRP	-	-	100	mVp-p	for VCC Note3 Note4,Note5	
Differential input threshold voltage	High	VTH	-	-	+100	mV	at VCM= 1.25V Note6,7
	Low	VTL	-100	-	-	mV	
Terminating resistance	RT	-	100	-	Ω	-	
Input voltage for DPS and FRC signals	High	VFH	0.7VCC	-	VCC	V	-
	Low	VFL	0	-	0.3VCC	V	
Input current for DPS and FRC signals	High	IFH	-	-	500	μA	-
	Low	IFL	-500	-	-	μA	

Note1: Checkered flag pattern [by IEC 61747-6]

Note2: Pattern for maximum current

Note3: This product works even if the ripple voltage levels are over the permissible values, but there might be noise on the display image.

Note4: The permissible ripple voltage includes spike noise.

Note5: The load variation influence does not include.

Note6: Common mode voltage for LVDS receiver

Note7: DC characteristics (LVDS receiver part)

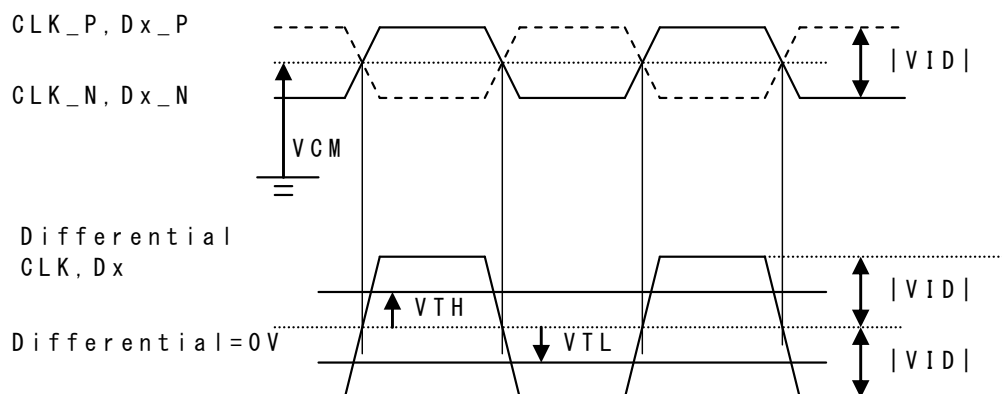

**5.2 Driving Backlight**

(Ta= 25°C)

Parameter	Symbol	min.	typ.	max.	Unit	Remarks	
Power supply voltage	VDD	10.8	12	13.2	V	Note1	
Power supply current	IDD	-	2755	-	mA	At the maximum luminance control	
Permissible ripple voltage	VRPD	-	-	200	mVp-p	for VDD Note3,Note4,Note5	
Input voltage for PWM signal	High	VDFH1	1.2	-	5.3	V	Note6
	Low	VDFL1	0	-	0.35	V	
Input voltage for BRTC signal	High	VDFH2	1.5	-	5.3	V	
	Low	VDFL2	0	-	0.8	V	
Input current for PWM signal	High	IDFH1	-	-	800	μA	
	Low	IDFL1	-800	-	-	μA	
Input current for BRTC signal	High	IDFH2	-	-	800	μA	
	Low	IDFL2	-800	-	-	μA	
PWM frequency	f <sub>PWM</sub>	200	-	10k	Hz	Note7, Note9	
PWM duty ratio	DR <sub>PWM</sub>	1	-	100	%	Note8, Note10,Note11	
PWM pulse width	tPWH	5	-	-	μs	Note10,Note11	
LED life time	Hr		50000		Hour	Note 11	

Note1: When designing of the power supply, take the measures for the prevention of surge voltage.

Note2: This value excludes peak current such as overshoot current.

Note3: The power supply lines (VDD and GND) may have ripple voltage during luminance control of LED. There is the possibility that the ripple voltage produces acoustic noise and signal wave noise in audio circuit and so on.

Note4: The permissible ripple voltage includes spike noise.

Note5: This product works if the ripple voltage levels are over the permissible values, but there might be noise on the display image.

Note6: See "**5.3 BLOCK DIAGRAM**".

Note7: A recommended f<sub>PWM</sub> value is as follows.

$$f_{PWM} = \frac{2n-1}{4} \times fv$$

(n = integer, fv = frame frequency of LCD module)

Note8:  $DR_{PWM} = \frac{tPWH}{tPW}$

tPWH: PWM pulse width, tPW: PWM dimming cycle (= 1/f<sub>PWM</sub>)

Note9: Depending on the frequency used, some noise may appear on the screen, please conduct a thorough evaluation.

Note10: While the BRTC signal is high, do not set the tPWH (PWM pulse width) is less than minimum value. It may cause abnormal working of the backlight. In this case, turn the backlight off and then on again by BRTC signal.

Note11: Regardless of the PWM frequency, both PWM duty ratio and PWM pulse width must be always more than the minimum values.

Note12: Optical performance should be evaluated at Ta=25°C. Only If LED is driven by high current, high ambient temperature & humidity condition. The life time of LED will be reduced. Operating life means brightness goes down to 50% of initial brightness. Typical operating life time is an estimated data.

**5.3 Block Diagram**

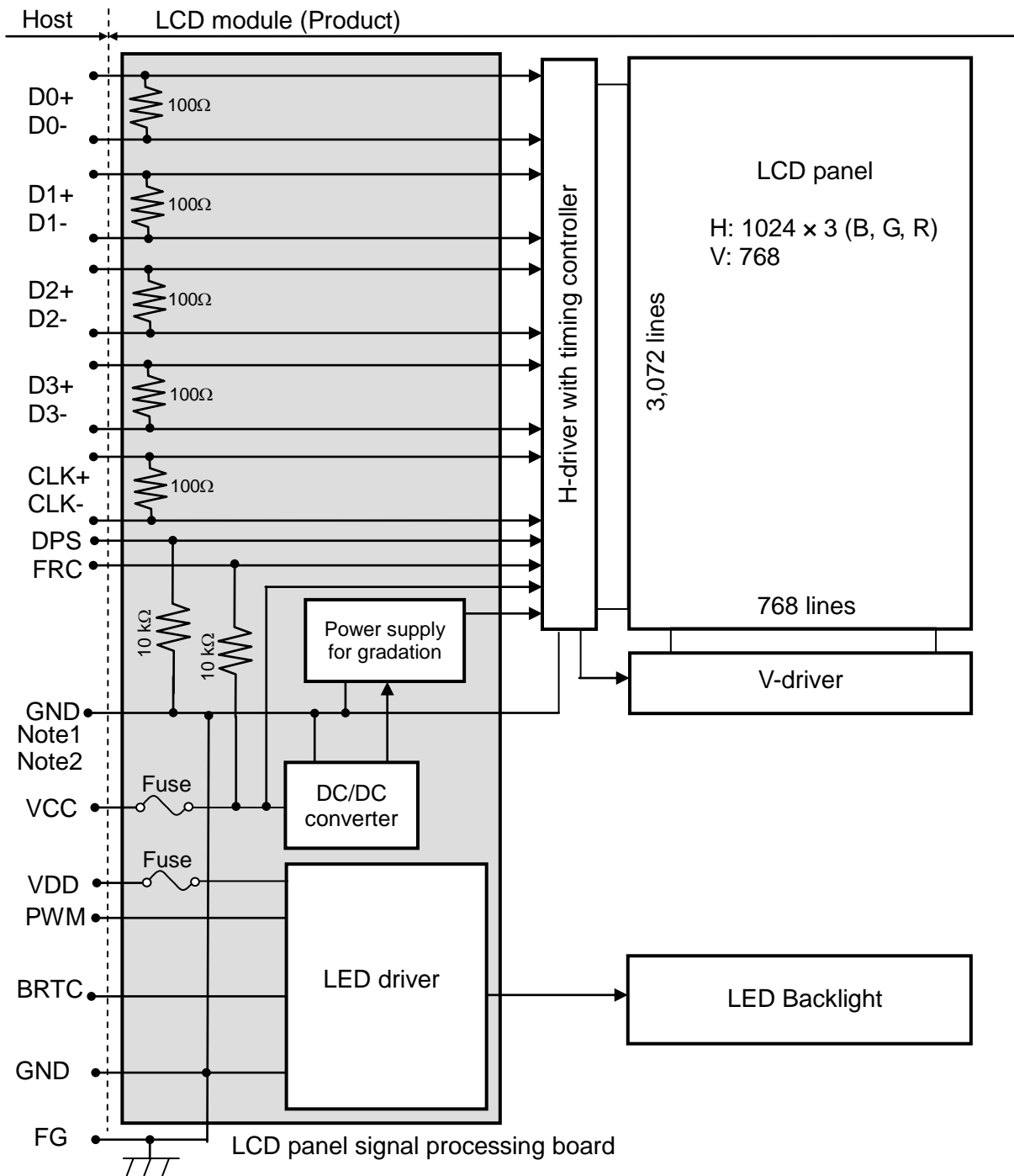

Note1: Relations between GND (Signal ground) and FG (Frame ground) in the LCD module are as follows.

GND - FG	Connected
----------	-----------

Note2: GND and FG must be connected to customer equipment's ground, and it is recommended that these grounds be connected together in customer equipment.

### 5.4 Fuse

Parameter	Fuse		Rating	Fusing current	Remarks
	Type	Supplier			
VCC	FCC16152AB	KAMAYA ELECTRIC Co., Ltd.	1.5A	3.0A	Note1
			36V		
VDD	SMFD1206P500	KAMAYA ELECTRIC Co., Ltd. PTTC	5.0A	10.0A	
			63V		

Note1: The power supply's rated current must be more than the fusing current. If it is less than the fusing current, the fuse may not blow in a short time, and then nasty smell, smoke and so on may occur.

## 6. Timing Chart

### 6.1 Timing Characteristics

(Note1, Note2, Note3)

Parameter		Symbol	min.	typ.	max.	Unit	Remarks	
CLK	Frequency	1/tc	58.4	65.0	67.9	MHz	15.385 ns (typ.)	
	Duty ratio	-	-			-	-	
	Rise time, Fall time	-				ns		
DATA	CLK-DATA	Setup time	-			ns	-	
		Hold time				ns		
	Rise time, Fall time	-				ns		
DE	Horizontal	Cycle	th	20.202	20.676	21.017	μs	48.363 kHz (typ.)
				1229	1,344	1372	CLK	
		Display period	thd	1024			CLK	-
	Vertical (One frame)	Cycle	tv	-	16.666	-	ms	60.0 Hz (typ.)
				793	806	825	H	
		Display period	tvd	768			H	
	CLK-DE	Setup time	-	-			ns	
Hold time		-	ns					
	Rise time, Fall time	-				ns		

Note1: Definition of parameters is as follows.

$$tc = 1CLK, th = 1H$$

Note2: See the data sheet of LVDS transmitter.

Note3: Vertical cycle (tv) should be specified in integral multiple of Horizontal cycle (th).

### 6.2 Input Signal Timing Chart

Horizontal timing

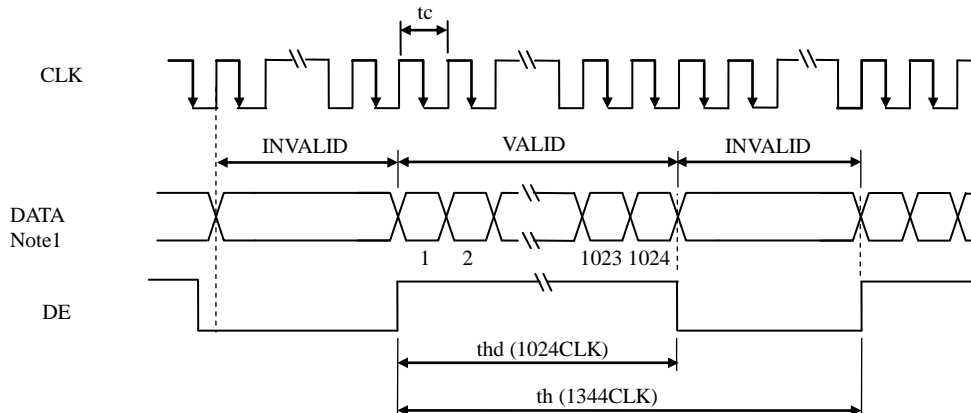

Vertical timing

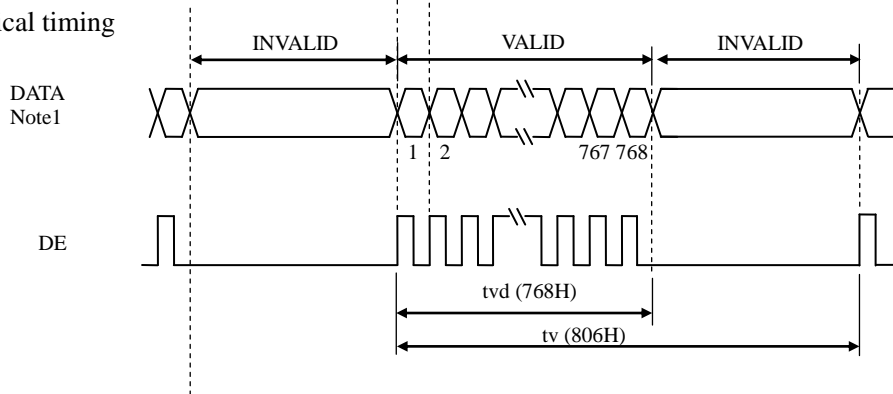

Note1: DATA = R0-R7, G0-G7, B0-B7 or R0-R5, G0-G5, B0-B5.

**6.3 Input Data Mapping**

(1) Input data signal: 8-bit

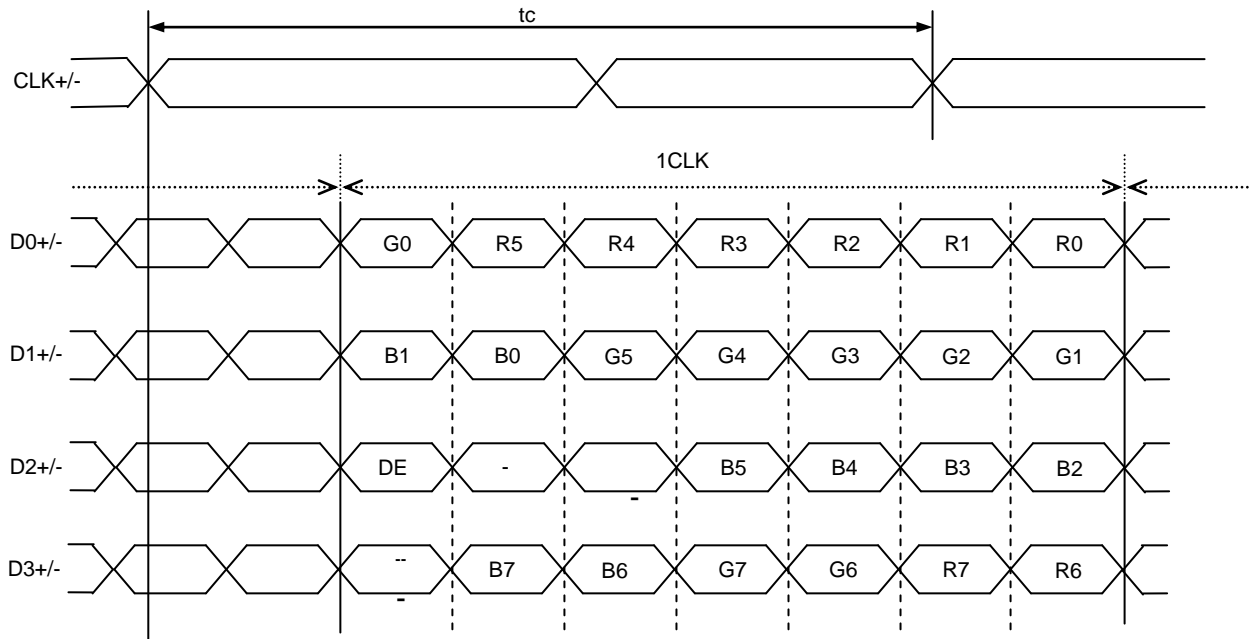

Note1: LSB (Least Significant Bit) - R0, G0, B0. MSB (Most Significant Bit) – R7, G7, B7

Note2: Twist pair wires with 100Ω (Characteristic impedance) should be used between LCD panel signal processing board and LVDS transmitter.

(2) Input data signal: 6-bit

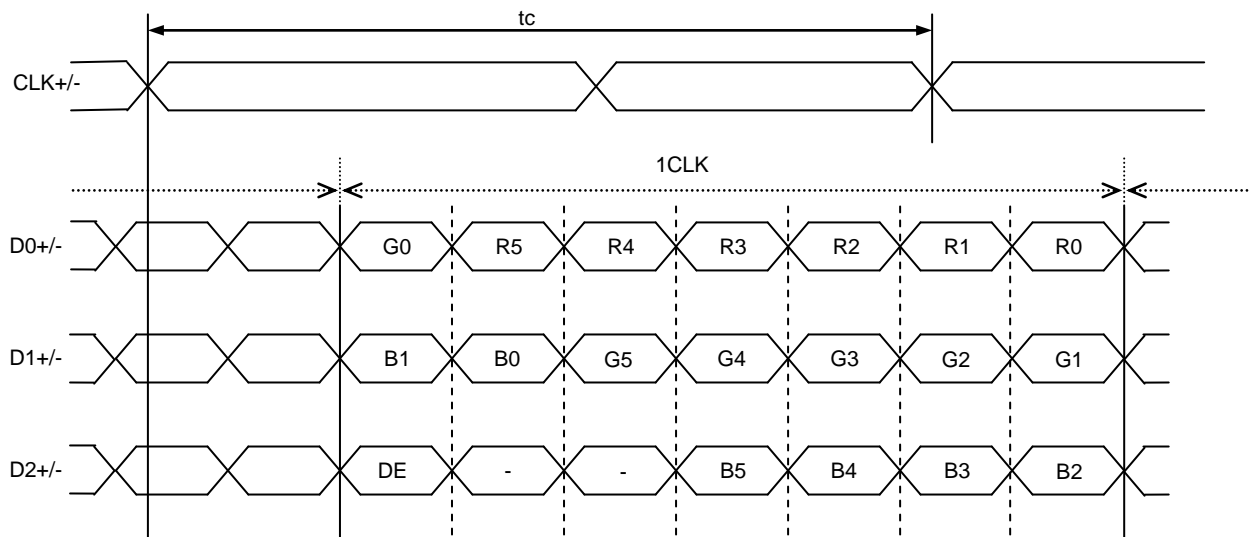

Note1: LSB (Least Significant Bit) - R0, G0, B0. MSB (Most Significant Bit) – R5, G5, B5

Note2: Twist pair wires with 100Ω (Characteristic impedance) should be used between LCD panel signal processing board and LVDS transmitter.

### 6.4 Display Colors and Input Data Signals

#### 6.4.1 Combinations of input data signals and FRC signal

This product can display 16,194,277 colors with 253 gray scales and 262,144 colors with 64 gray scales by combination of input data signals and FRC signal. See the following table.

Combination	Input data signals	CN1- Pin No.17 and 18	FRC terminal	Display colors	Remarks
①	8-bit	D3+/-	Low	16,194,277	Note1
②	6-bit	GND	High or Open	262,144	Note2

Note1: See "6.4.2 16,194,277 colors".

Note2: See "6.4.3 262,144 colors".

#### 6.4.2 16,194,277 colors

This product can display 16,194,277 colors with 253 gray scales by combination ①. (See "6.4.1 Combinations of input data signals and FRC signal".)

Also the relation between display colors and input data signals is as follows.

Display colors		Data signal (0: Low level, 1: High level)																							
		R7	R6	R5	R4	R3	R2	R1	R0	G7	G6	G5	G4	G3	G2	G1	G0	B7	B6	B5	B4	B3	B2	B1	B0
Basic Colors	Black	0	0	0	0	0	0	0	0	0	0	0	0	0	0	0	0	0	0	0	0	0	0	0	0
	Blue	0	0	0	0	0	0	0	0	0	0	0	0	0	0	0	0	1	1	1	1	1	1	0	0
	Red	1	1	1	1	1	1	0	0	0	0	0	0	0	0	0	0	0	0	0	0	0	0	0	0
	Magenta	1	1	1	1	1	1	0	0	0	0	0	0	0	0	0	0	1	1	1	1	1	1	0	0
	Green	0	0	0	0	0	0	0	0	1	1	1	1	1	1	0	0	0	0	0	0	0	0	0	0
	Cyan	0	0	0	0	0	0	0	0	1	1	1	1	1	1	0	0	1	1	1	1	1	1	0	0
	Yellow	1	1	1	1	1	1	0	0	1	1	1	1	1	1	0	0	0	0	0	0	0	0	0	0
	White	1	1	1	1	1	1	0	0	1	1	1	1	1	1	0	0	1	1	1	1	1	1	0	0
Red gray scale	Black	0	0	0	0	0	0	0	0	0	0	0	0	0	0	0	0	0	0	0	0	0	0	0	0
	dark	0	0	0	0	0	0	1	0	0	0	0	0	0	0	0	0	0	0	0	0	0	0	0	0
	↑					:							:								:				
	↓					:							:								:				
	Bright	1	1	1	1	1	0	1	1	0	0	0	0	0	0	0	0	0	0	0	0	0	0	0	0
	Red	1	1	1	1	1	1	0	0	0	0	0	0	0	0	0	0	0	0	0	0	0	0	0	0
Green gray scale	Black	0	0	0	0	0	0	0	0	0	0	0	0	0	0	0	0	0	0	0	0	0	0	0	0
	dark	0	0	0	0	0	0	0	0	0	0	0	0	0	0	0	1	0	0	0	0	0	0	0	0
	↑					:							:							:					
	↓					:							:							:					
	bright	0	0	0	0	0	0	0	0	1	1	1	1	1	0	1	1	0	0	0	0	0	0	0	0
	Green	0	0	0	0	0	0	0	0	1	1	1	1	1	1	0	0	0	0	0	0	0	0	0	0

Blue gray scale	Black	0 0 0 0 0 0 0 0	0 0 0 0 0 0 0 0	0 0 0 0 0 0 0 0
	dark	0 0 0 0 0 0 0 0	0 0 0 0 0 0 0 0	0 0 0 0 0 0 0 1
	↑			
	↓			
	bright	0 0 0 0 0 0 0 0	0 0 0 0 0 0 0 0	1 1 1 1 1 0 1 1
	Blue	0 0 0 0 0 0 0 0	0 0 0 0 0 0 0 0	1 1 1 1 1 1 0 0

6.4.3 262,144 colors

This product can display 262,144 colors with 64 gray scales by combination ②.  
 (See "6.4.1 Combinations of input data signals and FRC signal ".)  
 Also the relation between display colors and input data signals is as follows.

Display colors		Data signal (0: Low level, 1: High level)																	
		R5	R4	R3	R2	R1	R0	G5	G4	G3	G2	G1	G0	B5	B4	B3	B2	B1	B0
Basic colors	Black	0	0	0	0	0	0	0	0	0	0	0	0	0	0	0	0	0	0
	Blue	0	0	0	0	0	0	0	0	0	0	0	0	1	1	1	1	1	1
	Red	1	1	1	1	1	1	0	0	0	0	0	0	0	0	0	0	0	0
	Magenta	1	1	1	1	1	1	0	0	0	0	0	0	1	1	1	1	1	1
	Green	0	0	0	0	0	0	1	1	1	1	1	1	0	0	0	0	0	0
	Cyan	0	0	0	0	0	0	1	1	1	1	1	1	1	1	1	1	1	1
	Yellow	1	1	1	1	1	1	1	1	1	1	1	1	0	0	0	0	0	0
	White	1	1	1	1	1	1	1	1	1	1	1	1	1	1	1	1	1	1
Red gray scale	Black	0	0	0	0	0	0	0	0	0	0	0	0	0	0	0	0	0	0
	dark	0	0	0	0	0	1	0	0	0	0	0	0	0	0	0	0	0	0
	↑				:														
	↓				:														
	bright	1	1	1	1	0	1	0	0	0	0	0	0	0	0	0	0	0	0
Red	1	1	1	1	1	0	0	0	0	0	0	0	0	0	0	0	0	0	
Green gray scale	Black	0	0	0	0	0	0	0	0	0	0	0	0	0	0	0	0	0	0
	dark	0	0	0	0	0	0	0	0	0	0	1	0	0	0	0	0	0	0
	↑				:														
	↓				:														
	bright	0	0	0	0	0	0	1	1	1	1	0	1	0	0	0	0	0	0
Green	0	0	0	0	0	0	1	1	1	1	1	0	0	0	0	0	0	0	

Blue gray scale	Black	0	0	0	0	0	0	0	0	0	0	0	0	0	0	0	
		0	0	0	0	0	0	0	0	0	0	0	0	0	0	1	
	dark	0	0	0	0	0	0	0	0	0	0	0	0	0	1	0	
	↑				:				:				:				
	↓				:				:				:				
	bright	0	0	0	0	0	0	0	0	0	0	0	1	1	1	1	0
	0	0	0	0	0	0	0	0	0	0	0	1	1	1	1	1	0
Blue	0	0	0	0	0	0	0	0	0	0	0	1	1	1	1	1	1

**6.5 DISPLAY POSITIONS**

The following table is the coordinates per pixel (See "6.6 SCANNING DIRECTIONS".).

C (0, 0)

B	G	R
---	---	---

C( 0, 0)	C( 1, 0)	...	C( X, 0)	...	C(1022, 0)	C(1023, 0)
C( 0, 1)	C( 1, 1)	...	C( X, 1)	...	C(1022, 1)	C(1023, 1)
.	.	.	.	.	.	.
.	.	.	.	.	.	.
.	.	.	.	.	.	.
C( 0, Y)	C( 1, Y)	...	C( X, Y)	...	C(1022, Y)	C(1023, Y)
.	.	.	.	.	.	.
.	.	.	.	.	.	.
.	.	.	.	.	.	.
C( 0, 766)	C( 1, 766)	...	C( X, 766)	...	C(1022, 766)	C(1023, 766)
C( 0, 767)	C( 1, 767)	...	C( X, 767)	...	C(1022, 767)	C(1023, 767)

**6.6 SCANNING DIRECTIONS**

The following figures are seen from a front view.

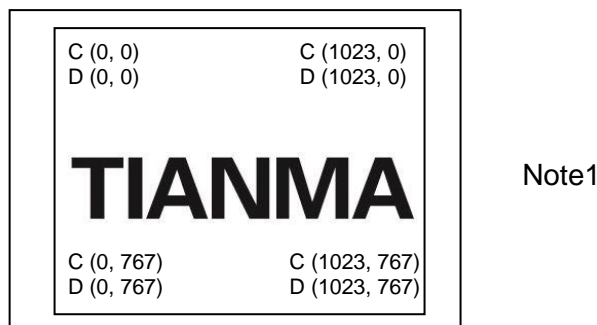

Figure1. Normal scan (DPS: Low or Open)

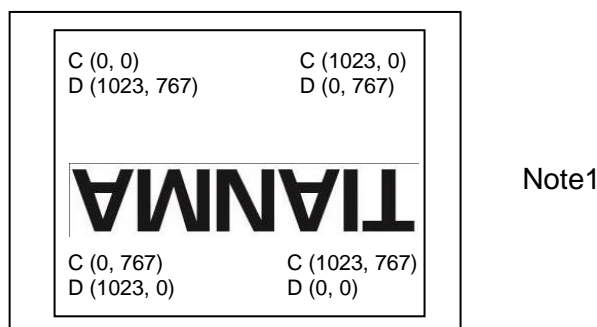

Figure2. Reverse scan (DPS: High)

Note1: Meaning of C (X, Y) and D (X, Y)

C (X, Y): The coordinates of the display position (See "6.5 DISPLAY POSITIONS".)

D (X, Y): The data number of input signal for LCD panel signal processing board

**6.7 Power On/Off Sequence**

6.7.1 LCD panel signal processing board

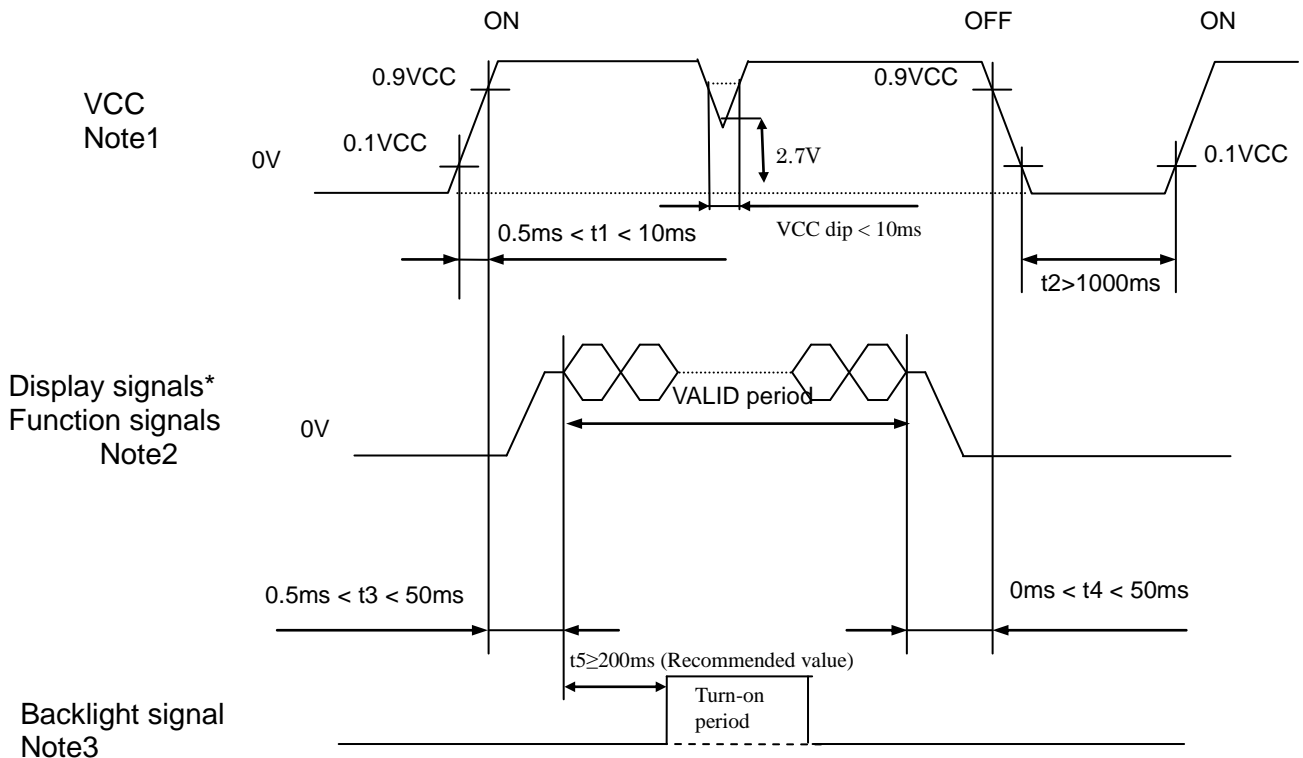

\* These signals should be measured at the terminal of 100Ω resistances.

Note1: If there is a voltage variation (voltage drop) at the rising edge of VCC below 3.0V, there is a possibility that a product does not work due to a protection circuit.

Note2: Display signals (D0+/-, D1+/-, D2+/-, D3+/- and CLK+/-) and function signals (DPS and FRC) must be set to Low or High-impedance, except the VALID period (See above sequence diagram), in order to avoid the circuitry damage.

If some of display and function signals of this product are cut while this product is working, even if the signal input to it once again, it might not work normally. If a customer stops the display and function signals, VCC also must be shut down.

Note3: In order to avoid unstable data display, the backlight is recommended to turn on within the VALID period of display. Recommended value:  $t_5 \geq 200\text{ms}$ .

6.7.2 LED driver board

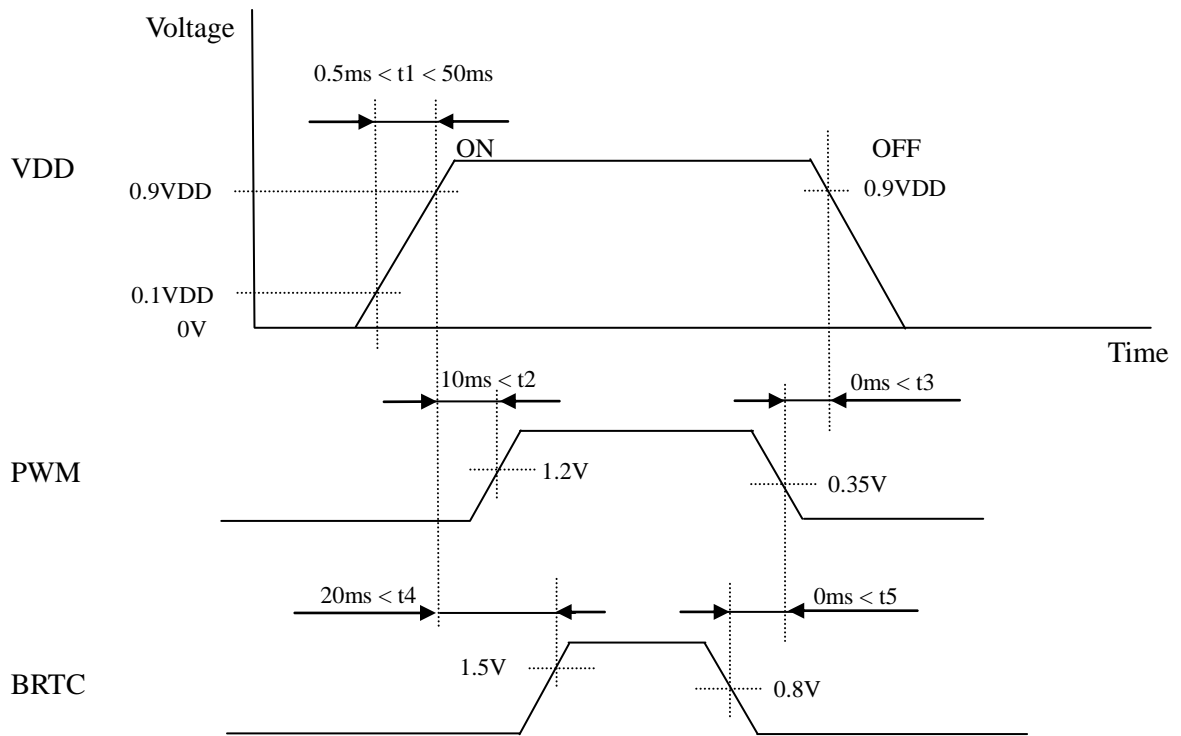

Note1: These are the display and function signals for LCD panel signal processing board.

## 7. Optical Characteristics

Ta=25°C

Item	Symbol	Condition	Min	Typ	Max	Unit	Remark	
View Angles	θT	CR ≥ 10	88	89	-	Degree	Note 2	
	θB		88	89	-			
	θL		88	89	-			
	θR		88	89	-			
Contrast Ratio	CR	θ=0°	600	1000	-	-	Note1 Note3	
Response Time	T <sub>ON</sub> +T <sub>OFF</sub>	25°C	-	25	40	ms	Note1 Note4	
Chromaticity	White	x	Backlight is on	0.267	0.317	0.367	-	Note5 Note1
		y		0.311	0.361	0.411		
	Red	x		0.594	0.644	0.694		
		y		0.291	0.341	0.391		
	Green	x		0.258	0.308	0.358		
		y		0.575	0.625	0.675		
	Blue	x		0.099	0.149	0.199		
		y		0.030	0.080	0.130		
Uniformity	U		70	75		%	Note1 Note6	
NTSC	-		65	72		%	Note 5	
Luminance	L		1500	1700	-	cd/m <sup>2</sup>	Note1 Note7	

### Test Conditions:

1. The ambient temperature is 25±2°C. humidity is 65±7%. PWM duty ratio is 100%.
2. The test systems refer to Note 1 and Note 2.
3. Contrast Ratio, Chromaticity, Uniformity, and Luminance is measured by SR-UL, SR-3AR or equivalent.
4. Response Time is measured by TRD-100, LCD-5200 or equivalent.

Note 1: Definition of optical measurement system.

The optical characteristics should be measured in dark room. After 20 minutes operation, the optical properties are measured at the center point of the LCD screen. All input terminals LCD panel must be ground when measuring the center area of the panel.

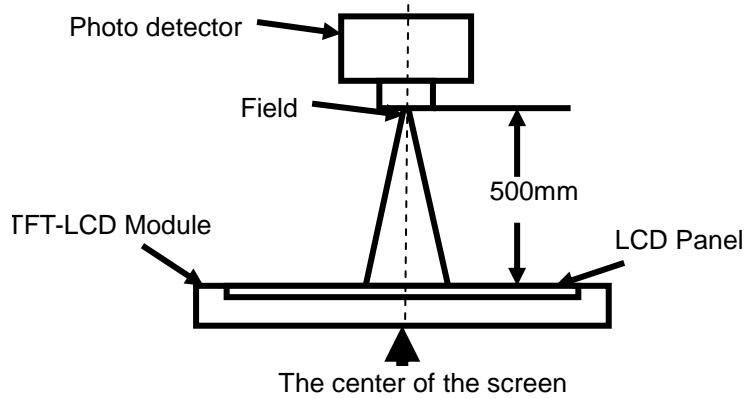

Note 2: Definition of viewing angle range and measurement system.

Viewing angle is measured at the center point of the LCD by LCD5200

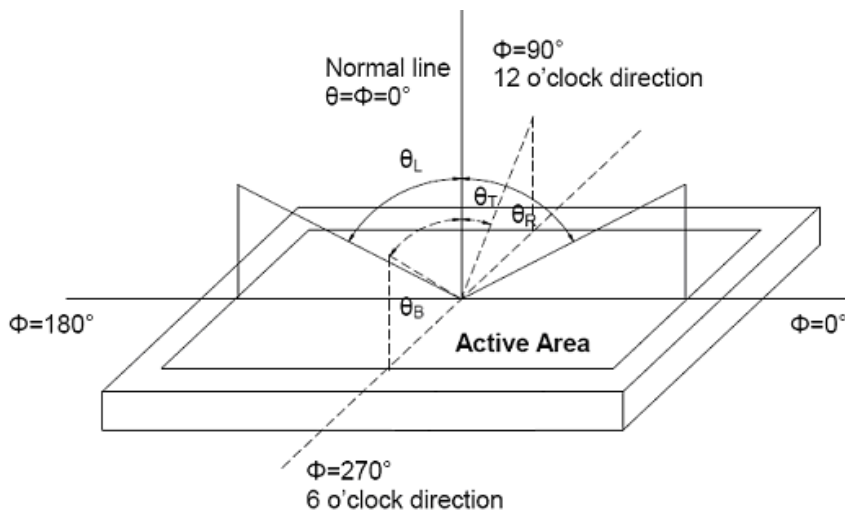

Fig. 1 Definition of viewing angle

**Note 3: Definition of contrast ratio**

The contrast ratio is calculated by using the following formula.

$$\text{Contrast ratio (CR)} = \frac{\text{Luminance of white screen}}{\text{Luminance of black screen}}$$

**Note 4: Definition of Response time**

The response time is defined as the LCD optical switching time interval between “Black” state and “White” state. Rise time (Ton) is the time between photo detector output intensity changed from 10% to 90%. And fall time (Toff) is the time between photo detector output intensity changed from 90% to 10%.

Product surface temperature: TopF= 29°C.

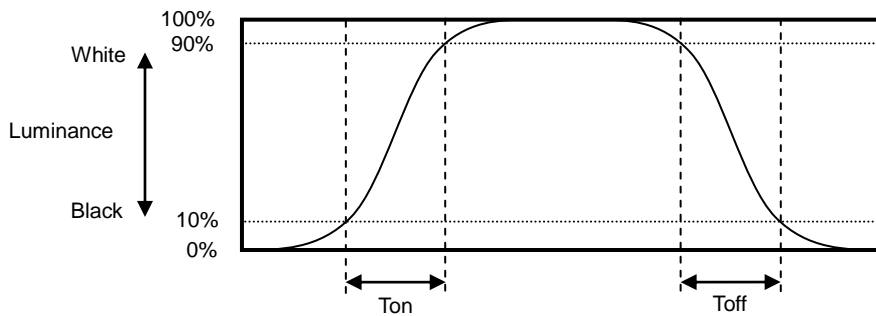

**Note 5: Definition of color chromaticity (CIE1931)**

Color coordinates measured at center point of LCD.

**Note 6: Definition of Luminance Uniformity**

Active area is divided into 9 measuring areas (Refer Fig. 2). Every measuring point is placed at the center of each measuring area.

$$\text{Luminance Uniformity}(U) = L_{\text{max}} / L_{\text{min}}$$

H-----Active area length V----- Active area width

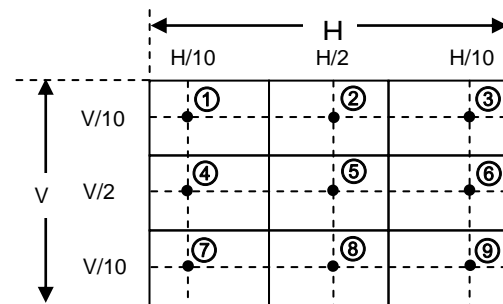

**Fig. 2 Definition of uniformity**

Lmax: The measured maximum luminance of all measurement position

Lmin: The measured minimum luminance of all measurement position.

**Note 7: Definition of Luminance**

Measure the luminance of white state at center point.

## 8. Environmental / Reliability Test

Test item	Condition	Judgment	Note1
High temperature and humidity (Operation)	① 60 ± 2°C, RH= 90%, 240hours ② Display data is white.	No display malfunctions	
High temperature (Operation)	① 70 ± 3°C, 240hours ② Display data is white.		
High temperature (Storage)	① 85 ± 3°C, 240hours ② Display data is white.		
Low temperature (Operation)	① -30 ± 3°C, 240hours ② Display data is white.		
Low temperature (Storage)	① -40 ± 3°C, 240hours ② Display data is white.		
Heat cycle (Operation)	① -20 ± 3°C 1hour 70 ± 3°C 1hour ② 50cycles, 4hours/cycle ③ Display data is white.		
Thermal shock (Non operation)	① -40± 3°C, 30minutes 80 ± 3°C, 30minutes ② 100cycles, 1hour/cycle ③ Temperature transition time is within 5 minutes.		
ESD (Operation)	① 150pF, 150Ω, Air: ±8kV contact: ±4kV ② 5 places ( Edge&Center ) Note2 ③ 5 times each places at 1 sec interval	No display malfunctions No physical damages	
Vibration (Non operation)	① 5 to 100Hz, 11.76m/s <sup>2</sup> ② 1 minute/cycle ③ X, Y, Z directions ④ 50 times each directions		
Mechanical shock (Non operation)	① 294m/s <sup>2</sup> , 11ms ② X, Y, Z directions ③ 3 times each directions		

Note1: Display and appearance are checked under environmental conditions equivalent to the inspection conditions of defect criteria.



## 10. Packing Drawing

<b>Panel Size</b>	15.0 inch	<b>Customer</b>		<b>Version</b>	1.0
<b>Module No.</b>	P1500XGF3MA00	<b>Main Display</b>		<b>Sub Display</b>	
<b>Display Type</b>		TFT			
<b>Resolution</b>		1024(RGB)×768			
<b>Module Demand Dimension</b>		326.5 x253.5 x12.0 mm			

## 二、组装内容说明

### 1.包装材料规格表(Packaging Material)

#### Per Carton

No	Item	Model (Material)	Dimensions(mm)	Unit Weight(Kg)	Quantity	Remark
1	LCM module	P1500XGF3MA00	326.5 × 253.5 × 12.0	1	10	
2	Partition board	Corrugated paper	384×256	0.02	2	
3	Anti-static Bag	LD-PE	435×325×0.05	0.001	10	Anti-static
4	EPP1	EPP	424×355×95	0.25	2	
5	EPP2	EPP	424×75×50	0.1	1	
6	Carton-inside	Corrugated paper	438×402×464	1.2	1	
7	Model Label	Paper		0.001	10	
8	Barcode Label	Paper		0.001	1	
9	Total weight	12.1Kg±5 %				

### 包装数量规格(Packaging Specification and Quantity)

每个纸箱所放Module数量为：10PCS

#### Stacking method (2×2×4)

纸箱堆叠数按2\*2/每层\*共3层

## **11. Precautions for Use of LCD Modules**

### **11.1 Handling Precautions**

11.1.1 The display panel is made of glass. Do not subject it to a mechanical shock by dropping it from a high place, etc.

11.1.2 If the display panel is damaged and the liquid crystal substance inside it leaks out, be sure not to get any in your mouth, if the substance comes into contact with your skin or clothes, promptly wash it off using soap and water.

11.1.3 Do not apply excessive force to the display surface or the adjoining areas since this may cause the color tone to vary.

11.1.4 The polarizer covering the display surface of the LCD module is soft and easily scratched. Handle this polarizer carefully.

11.1.5 If the display surface is contaminated, breathe on the surface and gently wipe it with a soft dry cloth. If still not completely clear, moisten cloth with one of the following solvents:

- Isopropyl alcohol
- Ethyl alcohol

Solvents other than those mentioned above may damage the polarizer. Especially, do not use the following:

- Water
- Ketone
- Aromatic solvents

11.1.6 Do not attempt to disassemble the LCD Module.

11.1.7 If the logic circuit power is off, do not apply the input signals.

11.1.8 To prevent destruction of the elements by static electricity, be careful to maintain an optimum work environment.

11.1.8.1 Be sure to ground the body when handling the LCD Modules.

11.1.8.2 Tools required for assembly, such as soldering irons, must be properly ground.

11.1.8.3 To reduce the amount of static electricity generated, do not conduct assembly and other work under dry conditions.

11.1.8.4 The LCD Module is coated with a film to protect the display surface. Be care when peeling off this protective film since static electricity may be generated.

### **11.2 Storage Precautions**

11.2.1 When storing the LCD modules, avoid exposure to direct sunlight or to the light of fluorescent lamps.

11.2.2 The LCD modules should be stored under the storage temperature range. If the LCD modules will be stored for a long time, the recommend condition is:

Temperature : 0°C ~ 40°C      Relatively humidity: ≤80%

11.2.3 The LCD modules should be stored in the room without acid, alkali and harmful gas.

### **11.3 Transportation Precautions**

The LCD modules should be no falling and violent shocking during transportation, and also should avoid excessive press, water, damp and sunshine.

# FORTEC GROUP

---

Our company network supports you worldwide with offices in Germany, Austria, Switzerland, the UK and the USA. For more information please contact:

## FORTEC GROUP

FORTEC Elektronik AG | Augsburgener Straße 2b | 82110 Germering  
+49 89 894450-0  
[info@fortecag.de](mailto:info@fortecag.de) | [www.fortecag.de](http://www.fortecag.de)

---

## FORTEC INTEGRATED

FORTEC Integrated GmbH | Augsburgener Straße 2b | 82110 Germering  
+49 89 894363-0  
[info@fortec-integrated.de](mailto:info@fortec-integrated.de) | [www.fortec-integrated.de](http://www.fortec-integrated.de)

## FORTEC POWER

FORTEC Power GmbH | Lise-Meitner-Straße 3 | 64560 Riedstadt  
+49 6158 8285-0  
[weborder@fortec-power.de](mailto:weborder@fortec-power.de) | [www.fortec-power.de](http://www.fortec-power.de)

## FORTEC UNITED KINGDOM

FORTEC Technology UK Ltd. | Osprey House | 1 Osprey Court  
Hinchingsbrooke Business Park | Huntingdon | Cambridgeshire | PE29 6FN  
+44 1480 411600 | [info@fortec.uk](mailto:info@fortec.uk) | [www.fortec.uk](http://www.fortec.uk)

## FORTEC UNITED STATES

FORTEC United States, Corp. | 87 Raynor Avenue Unit 1 | Ronkonkoma  
NY | 11779 | +1 631 5804360  
[info@fortec.us](mailto:info@fortec.us) | [www.fortec.us](http://www.fortec.us)

## FORTEC CZECH REPUBLIC

FORTEC Czech Republic s.r.o. | Přátelství 275 | 330 02 Dýšina  
+49 89 894363-0  
[info@fortec.cz](mailto:info@fortec.cz) | [www.fortec.cz](http://www.fortec.cz)

## FORTEC SWITZERLAND

FORTEC Switzerland AG | Bahnhofstraße 3 | 5436 Würenlos  
+41 44 7446111  
[info@fortec.ch](mailto:info@fortec.ch) | [www.fortec.ch](http://www.fortec.ch)

## FORTEC EGYPT

FORTEC Electronic Design and Solution Egypt SMLC | Linx Business Park  
Unit B318 | Smart Village | Giza Governorate  
[info@fortec.eg](mailto:info@fortec.eg) | [www.fortec.eg](http://www.fortec.eg)



Nottrot B.V. | A FORTEC GROUP Member  
Everdenberg 79  
4902 TT Osterhout | North Brabant  
+31 162 515458  
[info@nottrot.nl](mailto:info@nottrot.nl) | [www.nottrot.com](http://www.nottrot.com)